

IMPORTANT SAFETY NOTICE

This information is intended for use by individuals possessing adequate background of electrical, electronic and mechanical experience. Any attempt to repair a major appliance may result in personal injury and property damage. The manufacturer or seller cannot be responsible for the interpretation of this information, nor can it assume any liability in connection with its use.

AIR FLOW AND SEALS

Proper air flow through the dryer is essential for normal operation of the temperature control and safety systems. Air is PULLED into the cabinet from rear. A portion of this air is heated by the gas burner in the combustion chamber and is pulled up the rear duct into the diffuser. The remainder of this air enters the diffuser directly through vents and is mixed with the heated air. This hot air is PULLED through the drum rear, across the clothes load, through the lint trap and down the trap duct into the blower. From the blower the air is PUSHED out of the exhaust system.

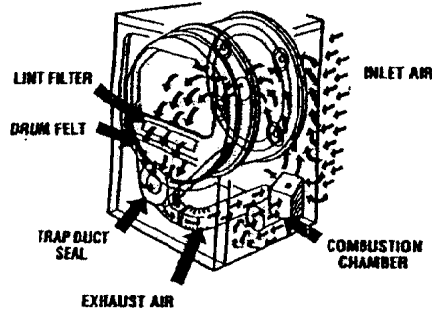

Any air leaks between the air inlet and the blower such as lower drum front felt or trap duct to cabinet front sealing will result in improper temperatures. The air being pulled down the trap duct to the drum outlet thermostat will be cooler than normal, giving this thermostat a false indication (delayed or no-trip). Leaks ahead of the blower will also reduce the volume of air across the combustion chamber causing hot spots and possible premature failure.

TRAP DUCT SEALING

To inspect the trap duct for proper sealing, remove the lint filter and took down into the duct. With a light examine the trap duct on all sides where it meets the dryer front for voids in sealing. Leaks may be sealed with permagum.

- WHEN FLEXIBLE DUCT IS USED, WE STRONGLY RECOMMEND METALLIC FLEXIBLE DUCT.
- EXHAUST DUCT MUST BE 100 mm (4 INCH) DIAMETER.
- FOR SPECIFIC EXHAUST SPECIFICATION, REFER TO INSTALLATION INSTRUCTION SUPPLIED WITH YOUR DRYER.

GENERAL TROUBLESHOOTING GUIDE; GAS DRYER

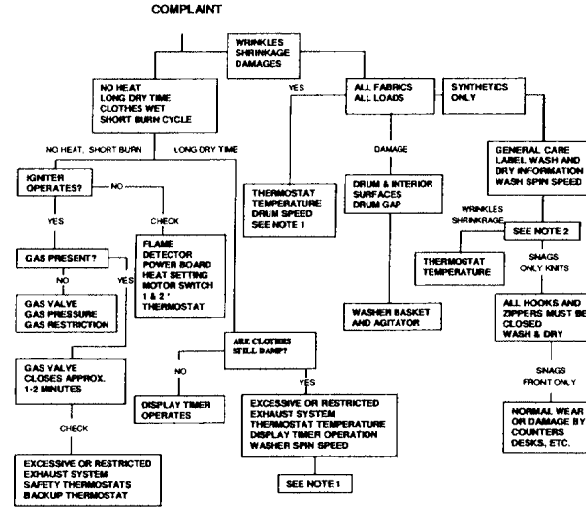

* SEE SCHEMATIC FOR PROPER SWITCH CONNECTIONS

NOTES:

1. Other factors contributing to long dry times, or clothes condition: load size, large bulky items, ambient temp., room size (if not exhausted outdoor), washer spin speed, washer rinse temperature, gas supply (restrictions), gas pressure.
2. Small loads: Less than 3 lbs. if not treated with destaticizer could develop a static charge if overdried and cling to drum surface (no tumble) causing wrinkles, shrinkage, or melting. Use a fabric softener (washer or dryer) or add 2 large bath towels to act as a buffer when drying.

SERVICE PARTS

Motor	120-60HZ (WE17M31)
Drive Belt	WE12M22
Idler Pulley	WE12M8
Drum Bearing Sleeve.....	WE1M462

LUBRICATION

WE25X46 Grease • Idler Bearings

SERVICE NOTE: Some replacement parts may have more terminal connections than the original part. Wire the new part to the same numbered terminals as the original part and disregard the unused terminals unless a special instruction is provided.

IMPORTANT

Reconnect all earthing devices. All parts of this appliance capable of conducting electrical current are earthed. If earthing wires, screws, straps clips, nuts or washers used to complete a path to earth are removed for service, they must be returned to their original position and properly fastened.

DRIVE BELT

The drum is rotated counterclockwise, as viewed from the front, at a speed of 47-51 RPM. Belt tension is maintained by a spring loaded idler pulley and driven by a pulley attached to the rear motor shaft.

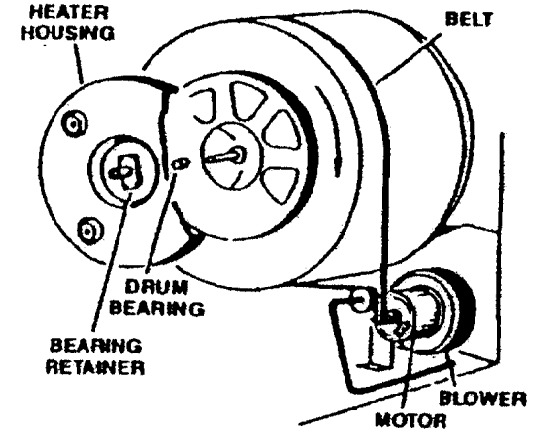

WHEN SERVICING THE DRYER

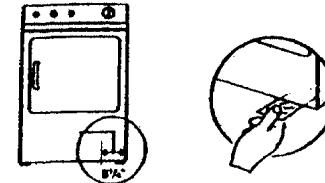

The igniter functioning and the flame can be seen through a viewer hole located in the base of the dryer. Use a mirror as shown in these figures.

DANGER: DISCONNECT ELECTRIC POWER SUPPLY BEFORE SERVICING

SCHEMATIC CAUTION

LABEL ALL WIRES PRIOR TO DISCONNECTION WHEN SERVICING CONTROLS. WIRING ERRORS CAN CAUSE IMPROPER AND DANGEROUS OPERATION. VERIFY PROPER OPERATION AFTER SERVICING.

THERMOSTAT	TEMPERATURE °F		TEMPERATURE °C	
	OPEN	CLOSE	OPEN	CLOSE
OUTLET CONTROL BACKUP	155 ± 5	155 ± 5	74 ± 3	68 ± 3
MULTI-SAFETY	300 ± 8	260 ± 12	149 ± 4	127 ± 7

LEGEND

- X = CONTACTS ACTIVATED
- O = CONTACTS DEACTIVATED
- TC = THERMISTOR CONTROLLED
- TVS = TRANSIENT VOLTAGE SUPPRESSOR

K OHMS	THERMISTORS RESISTANCE VALUES AT	
	°F	°C
78 - 82	86	30
98 - 102	77	25
138 - 122	69	21

DRY TEMPERATURE	RELAYS	
	K100-40 MOTOR	K100-40 GAS VALVE
ANTIBACTERIAL (SOME MODELS)	X	TC
HIGH	X	TC
MEDIUM	X	TC
LOW	X	TC
EXTRA LOW	X	TC
NO HEAT (SOME MODELS)	X	O

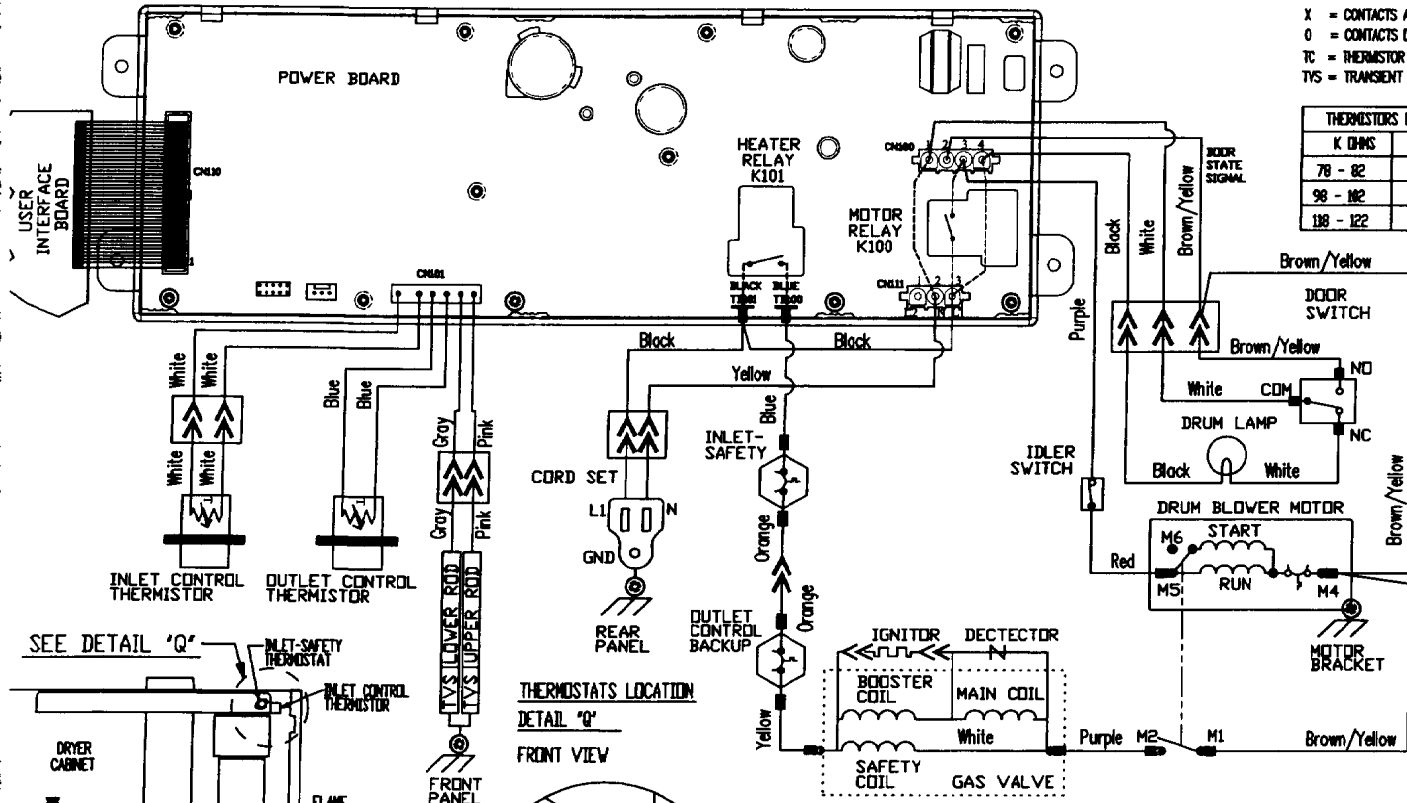

THERMOSTATS LOCATION DETAIL 'Q'

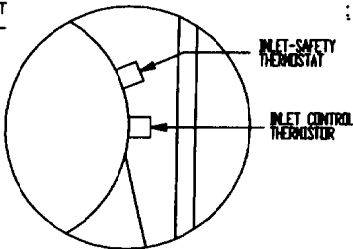

WHEN SERVICING THE DRYER

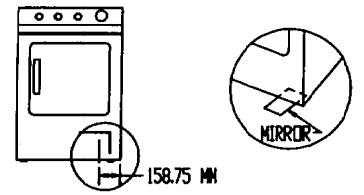

THE IGNITOR FUNCTIONING AND THE FLAME CAN BE SEEN THROUGH A VIEWER HOLE LOCATED IN THE BASE OF THE DRYER. USE A MIRROR AS SHOWN IN THESE FIGURES.

- NOTES**
- SOLDER TRACES ON PC BOARD
 - - - GANGED CENTRIFUGAL SWITCH
 - POINT TO POINT TERMINALS
 - CONNECTOR JUNCTION
 - ⊙ SCREWS (BONDING AND GROUNDING)

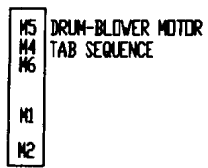

P002 P002 P002 P002 P002 P002 P002 P002

212D1204 P002
 PUB # 31-16123
 REV.0

